

# SMART LIGHT evo | SMART PLUS AC-evo

Compactness for the smallest spaces

Capacity (kg): 1500 / 2000    Lifting Height (mm): 200

## SMART LIGHT evo / SMART PLUS AC-evo

Maximum compactness, versatility and elegance for agile, quick and safe handling operations.

The smallest device within its category, compact as a manual pallet truck, it is the best solution to get out of small spaces, where agility and compactness are the fundamental features being required.

The aforesaid features make it particularly suitable for handling operations on lorries and articulated lorries, which are characterised by very small manoeuvring spaces.

It is available in 1500 Kg (Smart Light) and 2000 Kg (Smart Plus) versions.

### AC technology

- + Performance
- + Driving control
- Service Costs



## POWERED PALLET TRUCKS

Features in detail:



### NEW DR EVO DRIVE STEERING:

Includes LED battery charge indicator, "turtle" switch for variable speed control, precision proportional lifting / lowering control and safety reversing (crushproof) switch.



### TRACTION AND STABILITY:

Structure with 5 contact points and shock-absorber system for perfect grip by the driving wheel in case of floor irregularities. AC traction drives (only for SMART PLUS) offer maximum responsiveness in starting and during braking.

# SMART DL AC-evo

Multi-functionality

Capacity (kg): 1800-1050 / 1800-700    Lifting Height (mm): 200-1400 / 200-700

## SMART DL AC-evo 180/14

In addition to lifting to 200 mm from the floor like a common pallet truck, the SMART DL's forks lift independently to 1400 mm. Combine traditional pallet handling operations with additional functions such as storage and picking from shelves and unloading motor vehicles. The lifting of the support legs allows simultaneous handling of two pallets and passing over ramps and other obstacles on the floor.

### AC technology

- + Performance
- + Driving control
- Service Costs



## SMART DL AC-evo 180/07

Version equipped with first lifting stage up to 200 mm and secondary fork lifting up to 700 mm.

## POWERED PALLET TRUCKS

Features in detail:



### Handling of two pallets.



### Motor Vehicle Loading and Unloading Operations.



### Storage and picking of goods.





# SMART LIGHT evo - SMART PLUS AC-evo

model	150/200	200/200
Q	Kg 1500	2000
C	mm 600	600
I	mm 1150 - 1000 - 800	1150 - 1000 - 800
L	mm 1615	1615
X	mm 205	205
X2	mm 190	190
Y	mm 1220	1220
L2	mm 465	465
M	mm 560	560
N	mm 180	180
h1	mm 1440	1440
h3	mm 200	200
B	mm 750	750
WA	mm 1430	1430

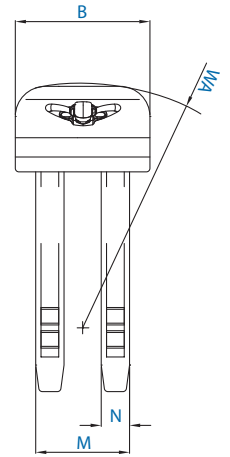
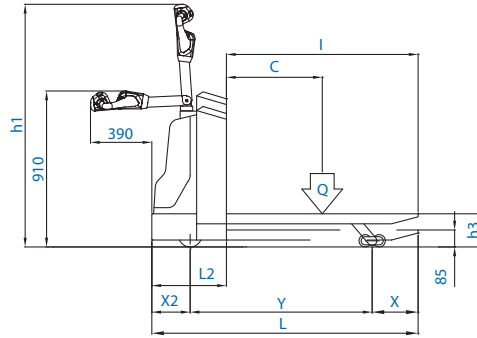

## STANDARD EQUIPMENT

- AC three-phase technology traction motors (only for Smart Plus version) • Braking in release contra flow (only for Smart Light)
- High-frequency electronic plant 24V with microprocessor fault research (only for Smart Light) • Electronic plant 24V with controller with mosfet technology complete with inverter and microprocessor fault research (only for Smart Plus version) • Regenerative braking with consumption reduction and temperature control of the traction motor (only for Smart Plus version) • Electronic battery charger 24V 20A with microprocessor • Forks control by push-buttons • Electric end stroke • Proof-seal bearings with pins with self lubricating sintered bushings • Electromagnetic parking brake • Fixed forks length mm. 800-1000-1150 • Shock absorber on driving-wheel • Exhausted battery warning-indicator • Side wheels with extra-heavy castors • Tandem or single fork rollers • DR-EVO Steering • Safety components • N. 2 batteries 12V 155Ah (for Smart Plus) or N. 2 batteries 12V 120 Ah (for Smart Light); traction battery 24V 130Ah on request

# SMART DL AC-evo 180/07

model	180/07
Q1	Kg 750
Q2	Kg 1800
C	mm 600
I	mm 1150
L	mm 1755
X	mm 170
X2	mm 185
Y	mm 1400
L2	mm 605
M	mm 566
N	mm 188
h1	mm /
h3	mm 700
B	mm 750
WA	mm 1610

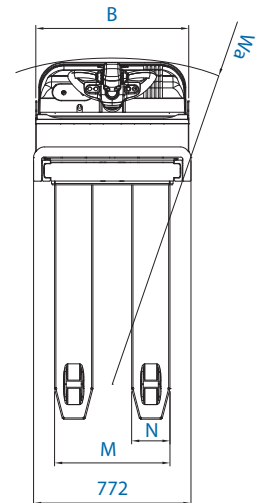
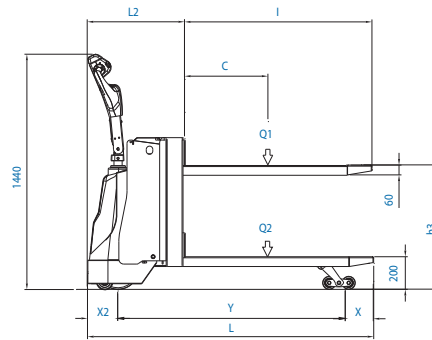

# SMART DL AC-evo 180/14

model	180/14
Q1	Kg 1050
Q2	Kg 1800
C	mm 600
I	mm 1150
L	mm 1755
X	mm 170
X2	mm 185
Y	mm 1400
L2	mm 605
M	mm 566
N	mm 188
h1	mm 1170
h3	mm 1400
h4	mm 1830
B	mm 750
WA	mm 1610

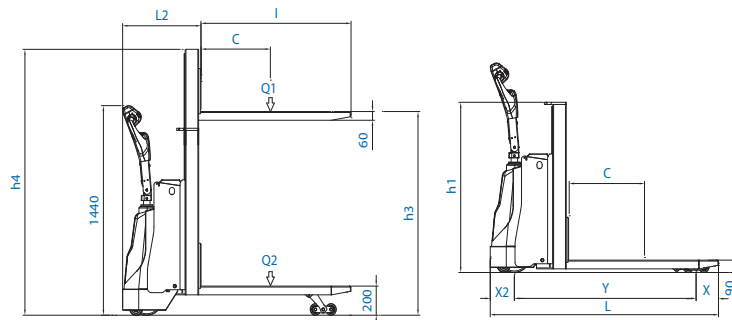

## STANDARD EQUIPMENT

- AC three-phase technology traction motors • Electronic plant 24V with controller with mosfet technology complete with inverter and microprocessor fault research • Regenerative braking with consumption reduction and temperature control of the traction motor • Electronic battery charger 24V 20A with microprocessor • Forks control by push-buttons • Electric end stroke • Proof-seal bearings with pins with self lubricating sintered bushings • Electromagnetic parking brake • Fixed forks length mm. 1150 • Shock absorber on driving-wheel • Exhausted battery warning-indicator • Side wheels with extra-heavy castors • Tandem fork rollers • DR-EVO Steering • Safety components • Traction Battery 24V 130AH MBS